

## **Blotting Techniques**

**Lesson Prepared Under MHRD project “ National Mission  
on Education Through ICT”**

**Discipline: Botany**

**Paper: Plant Biotechnology**

**National Coordinator: Prof. S.C. Bhatla**

**Lesson: Blotting Techniques Department/College: Department of  
Genetics, University of Delhi, South Campus**

**Lesson Developer: Vinee Khanna**

**Lesson Reviewer: Dr Manoj K. Sharma**

**School of Biotechnology**

**Jawaharlal Nehru University**

**Language Editor: Namrata Dhaka**

**Department/College: Department of Genetics, University of Delhi,  
South Campus**

**Lesson Editor: Dr Rama Sisodia, Fellow in Botany ILL**

# Blotting Techniques

## Table of Contents

### Chapter: Blotting methods

- **Introduction**
  - **Southern blotting**
    - **Introduction**
    - **Principle**
    - **Methodology**
      - **Preparation of genomic DNA**
      - **DNA separation**
      - **Blotting methods**
      - **DNA-DNA hybridization**
      - **Detection**
    - **Applications**
    - **Limitations**
  - **Northern Blotting**
    - **Introduction**
    - **Procedure**
      - **Preparation of RNA**
      - **DNA separation**
      - **Blotting methods**
      - **DNA-DNA hybridization**
      - **Detection**
    - **Applications**
    - **Advantages**
    - **Disadvantages**
  - **Western Blotting**
    - **Introduction**
    - **Principle**
    - **Procedure**
      - **Sample preparation**
      - **Separation on gel**
      - **Transfer to the blotting membrane**
      - **Detection**

## Blotting Techniques

- Applications
- Glossary
- Exercise
- References
- Further reading



## Blotting Techniques

### Learning Outcomes

The following chapter would help you to familiarize with the following:

- Methodologies involved in DNA, RNA and protein sample preparations for hybridization.
- Blotting methods and transfer membranes used.
- Different methods of detection.
- Applications of the various blotting methods.
- Advantages and disadvantages of the various blotting techniques.



# Blotting Techniques

## Introduction

The oldest method of blotting was given by Edwin Southern in the year 1973 (refer to the figure). In this method the DNA was fragmented with endonucleases and run on an agarose gel. The separated bands were then transferred to a nylon membrane using the capillary action method. The radiolabelled probes were hybridized to the membrane and analyzed on the photographic film. This method is the basis of all the blotting methods available today. Each of the methods has been modified according to the sample analyzed and to increase the efficiency of the data obtained.

Blotting involves four major steps:

- Separation of sample by gel electrophoresis.
- Immobilization on a solid support.
- Binding of a probe on the target.
- Detection and analysis of the target by visualization.

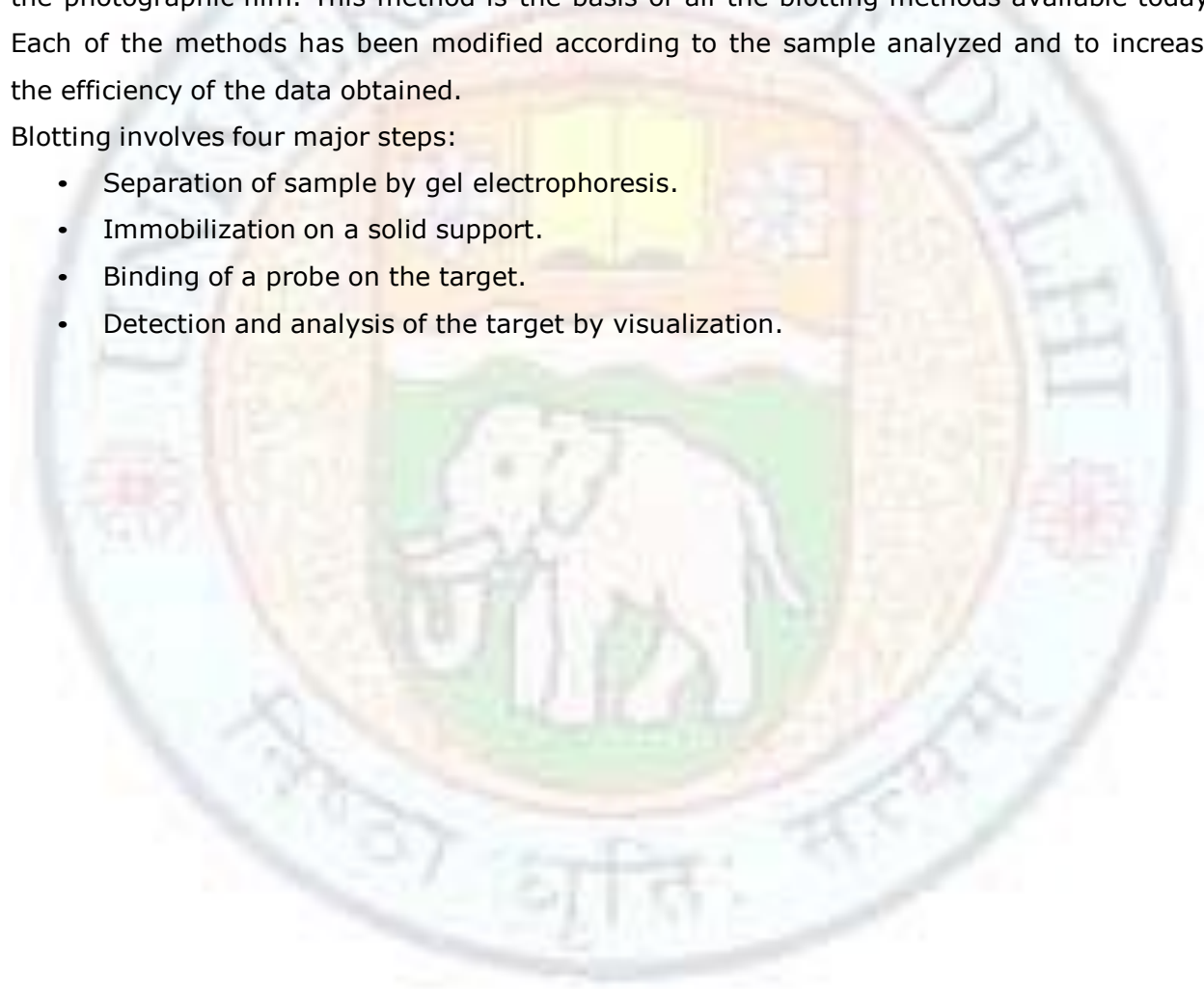

## Blotting Techniques

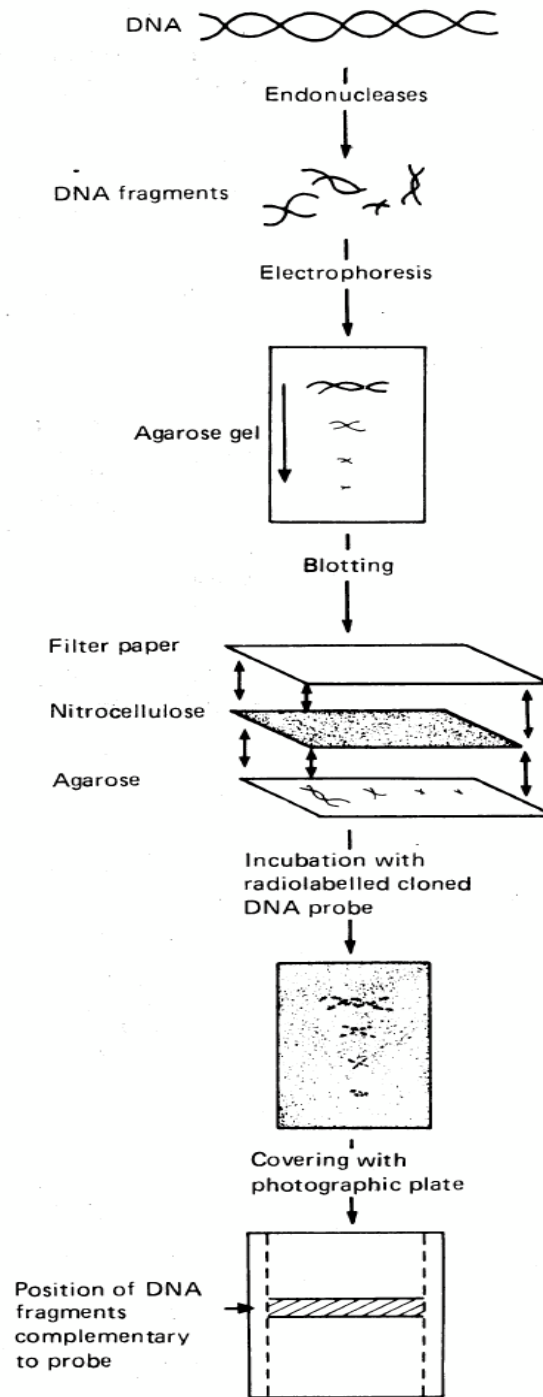

**Figure:** The old method of Southern blotting.

Source: Blotting techniques for the study of DNA, RNA, and proteins. Peter C Hayes, C Roland Wolf, John D Hayes. Br Med j 1989; 299:965-8.



# Blotting Techniques

There are three main techniques of blotting:

- Southern blotting- It involves immobilization of DNA on a solid support and target DNA identification with a probe DNA.
- Northern blotting- It involves immobilization of mRNA on a solid support and target identification by DNA probes.
- Western blotting- It involves immobilization of proteins on a solid support and target identification by specific antibodies as probes.

## Southern Blotting

### Introduction

Southern Blotting was developed by Sir Edwin Southern in 1973. It was named after him. It involves separation of uncut DNA on the gel and their subsequent transfer to a solid support or membrane. The DNA is hybridized to the membrane and is then attached to the labeled DNA probes. As discussed earlier, the old method of blotting is now used with certain modifications.

Modifications to the early method:

- Efficient transfer methods have been devised e.g. vacuum blotting, bidirectional blotting, and transfer in alkaline buffers.
- Probe labeling for higher specificity.
- Blocking agents to prevent non specific binding to the membrane.
- Use of sensitive detection techniques.

### Principle

The principle behind this method is the separation of uncut DNA on a solid gel based matrix. The separated fragments are then transferred to a nylon membrane. The original method used by Southern was to transfer DNA through capillary transfer to a nitrocellulose sheet. The method used today is basically the same with certain modifications.

# Blotting Techniques

## Methodology

1. Preparation of genomic DNA
2. DNA separation
3. Blotting methods
4. DNA-DNA hybridization
5. Detection

### 1. Preparation of genomic DNA

The DNA is extracted using the cell lysis method.

- ✓ The cells are lysed and the contents are treated with protease and RNAse to degrade the proteins and RNA in the sample.
- ✓ The cell debris is precipitated and discarded.
- ✓ The supernatant is treated with ethanol to precipitate the DNA.
- ✓ The DNA is then fragmented using restriction enzymes so that the size of the DNA is decreased and the fragments can be separated and used further.

#### DNA Extraction

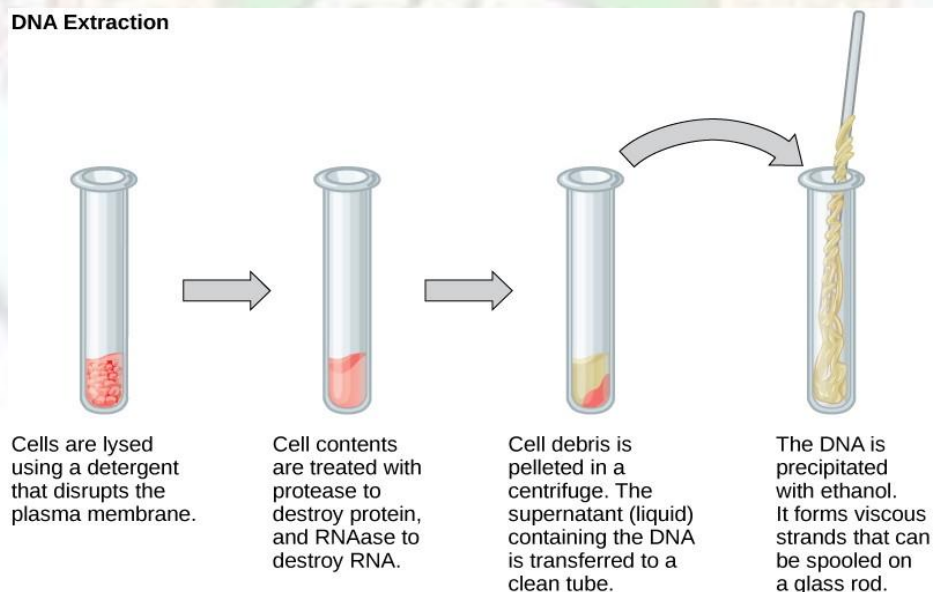

**Figure:** Preparation of DNA sample.

Source: <http://cnx.org/content/m44552/latest/?collection=col11448/1.9> (cc)

### 2. DNA separation



## Blotting Techniques

- ✓ The sample is treated with a restriction enzyme to break the DNA into smaller molecules.
- ✓ The fragments are separated on the gel according to their sizes.
- ✓ The gel is treated with 0.5M NaOH to denature the double stranded DNA.

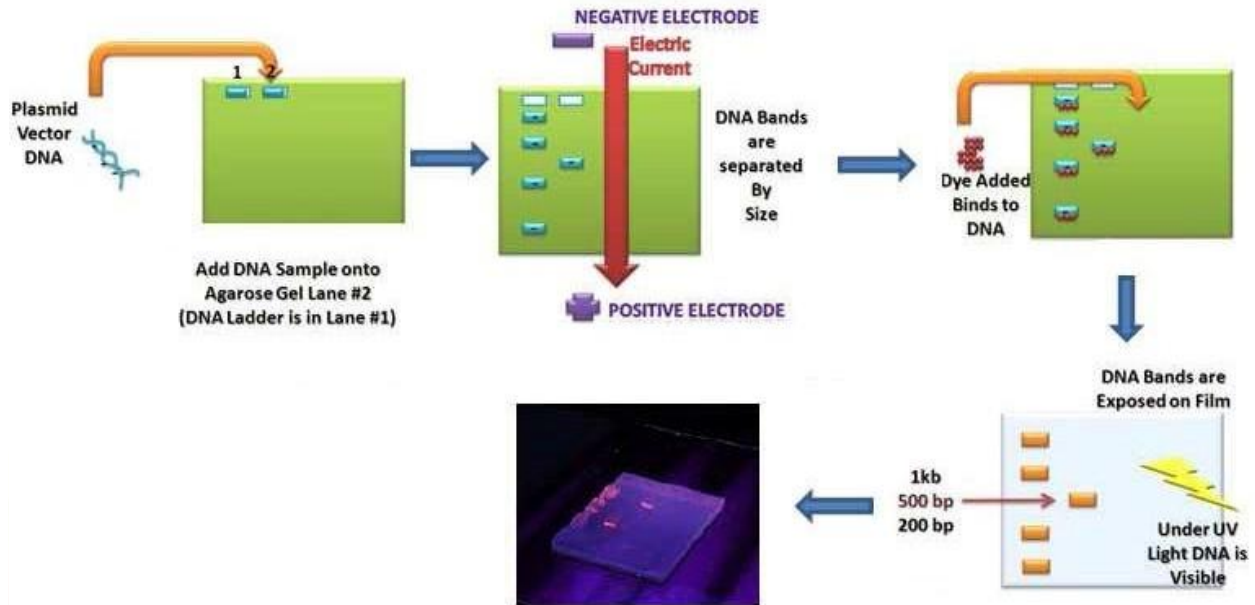
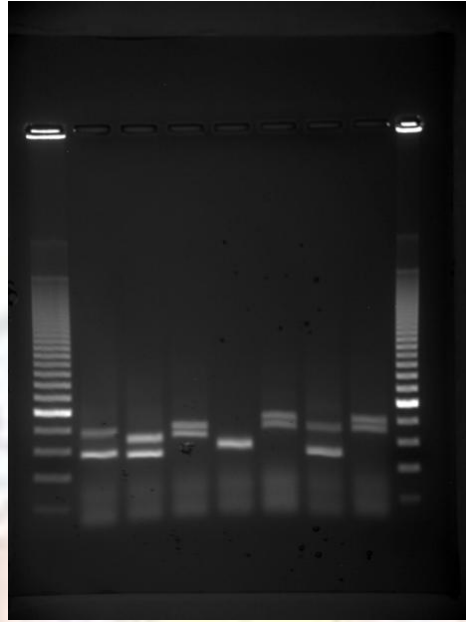

**Figure:** Method of agarose gel electrophoresis

Source: Yılmaz, Muhittin, Cem Ozic, and İlhami Gok. "Principles of Nucleic Acid Separation by Agarose Gel Electrophoresis."

<http://cdn.intechopen.com/pdfs-wm/35089.pdf> (cc)

## Blotting Techniques



**Figure:** DNA separation on an agarose gel. The first and the last lanes show DNA ladders which are used as size markers and the lanes in between show bands obtained from different DNA samples.

Source: <http://cnx.org/content/m44552/latest/?collection=col11448/1.9> (cc)

### 3. Blotting methods

#### • Membranes

- ✓ Nitrocellulose membrane is most commonly used to transfer the DNA from the gel. The gel is covered with the nitrocellulose paper along with a layer of filter papers.
- ✓ A weight is put over the apparatus to aid in rapid diffusion of the DNA to the membrane.
- ✓ The membrane is then treated with UV light or heat to fix the DNA by cross linking.

Nitrocellulose membrane- It is a high affinity membrane used to immobilize the DNA/RNA or proteins. It has high binding capacity useful for blotting techniques.

Disadvantages of Nitrocellulose membrane:

- Its binding efficiency to DNA is low.
- The nucleic acids are bound by hydrophobic interactions and not covalent linkages.

## Blotting Techniques

- They become brittle on baking at 80°C.
- It requires careful storage.

- **Methods of transfer**

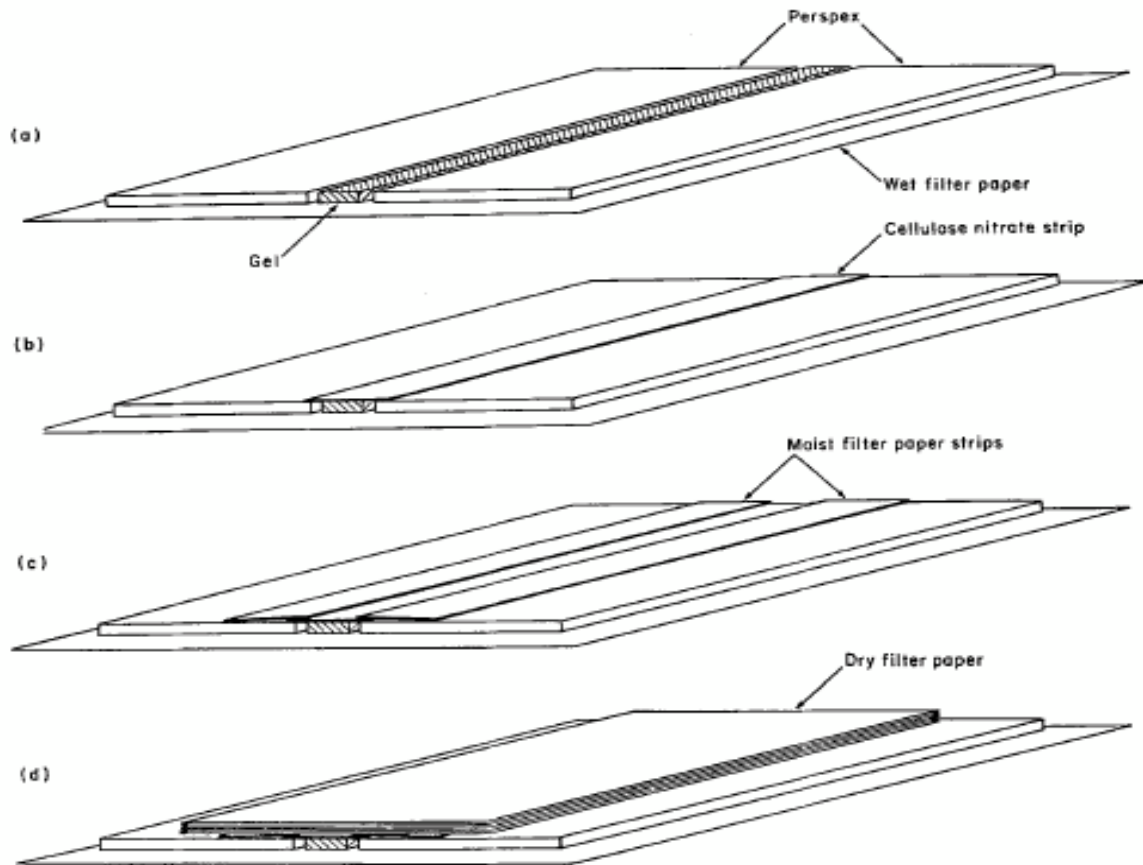

FIG. 1. Steps in the procedure for transferring DNA from agarose gels to cellulose nitrate strips.

**Figure:** The steps in the transfer of DNA from the gel to the membrane.

Source: <http://www.sciencedirect.com/science/article/pii/S0022283675800830#>

**Upward capillary transfer-** The DNA is transferred from the gel to the membrane in an upward flow.

## Blotting Techniques

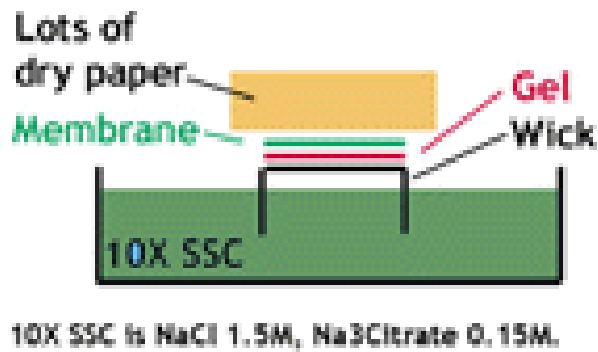

**Figure:** Upward capillary transfer.

Source: <https://askabiologist.asu.edu/southern-blotting> (cc)

- a. **Downward capillary transfer-** DNA is absorbed on to the membrane placed below the gel and the alkaline buffer flows in the downward direction. The transfer is rapid in this case as it is along the gravity therefore there is efficient migration.

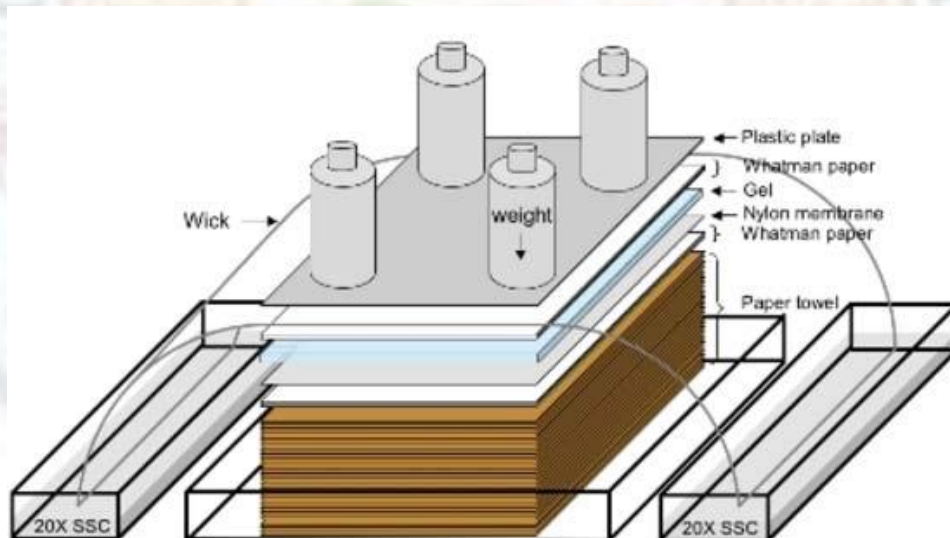

**Figure:** Downward capillary transfer.

Source: <https://askabiologist.asu.edu/southern-blotting> (cc)

- b. **Two way capillary transfers-** It can be used when there is high concentration of DNA. This uses simultaneous transfer from the gel to the two membranes. It is not used when high sensitivity is needed. It consists of two

## Blotting Techniques

buffer systems connected to a pile of whatmann papers stacked on the gel and the membrane.

- c. **Electrophoretic transfer**- It consists of the application of electric field to enable and enhance the transfer of the sample from the gel and the membrane. This requires high voltage to enable the transfer of DNA to the membrane. It results in heating of the buffer and affects the transfer of DNA. Some cooling devices are provided but are not efficient.
- d. **Vacuum transfer**- The membrane is placed over a vacuum chamber and the buffer drawn transfers the DNA onto the membrane. It is more efficient, fast and increases the hybridization signal.

### 4. DNA-DNA hybridization

- ✓ After the transfer of the sample to the membrane the remaining active sites on the membrane are blocked. This enhances the binding of the probes to the fragmented sample DNA.
- ✓ The membrane is treated with the radioactive labeled probe which is complimentary to the target sequence.
- ✓ The membrane is incubated for several hours and then washed to remove the excess probes attached.

**Probe** - It is a single DNA fragment with a specific sequence which is complimentary to the target sequence. It is labeled either by incorporating radioactivity or an enzyme linked or fluorescent molecule.



## Blotting Techniques

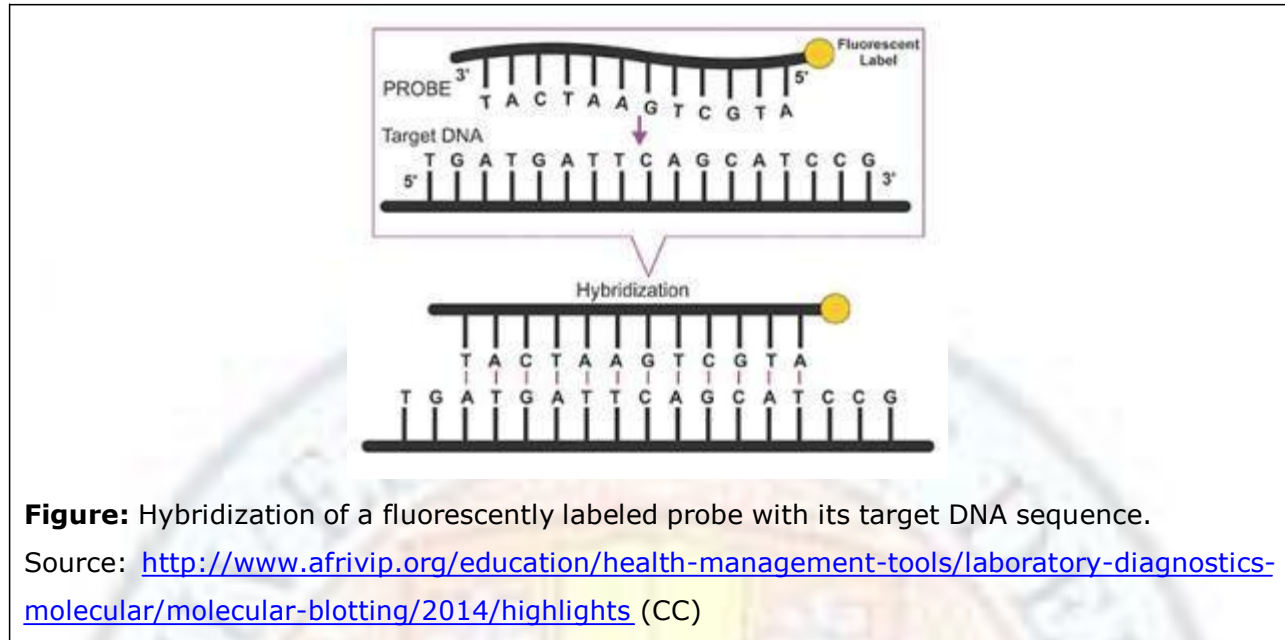

**Figure:** Hybridization of a fluorescently labeled probe with its target DNA sequence.

Source: <http://www.afrivip.org/education/health-management-tools/laboratory-diagnostics-molecular/molecular-blotting/2014/highlights> (CC)

### 5. Detection

The membrane is then placed over an X-Ray film and analyzed by autoradiography for a fluorescent or radioactive probe or by development of color in case of chromogenic dye.

### Applications

- **Diagnosis of genetic disorders**

It can be used to detect gene mutations and rearrangements in diseases. For example, diagnosis of sickle cell anemia A-T change in b unit of hemoglobin (glu to val) can be detected. The probe designed hybridizes to the sickle cell anemia variant and not the normal individuals. In the diagram given below the black represents the diseased individual. The specific bands (3kb and 2kb) in the diseased individuals act as a marker to diagnose the patients.

## Blotting Techniques

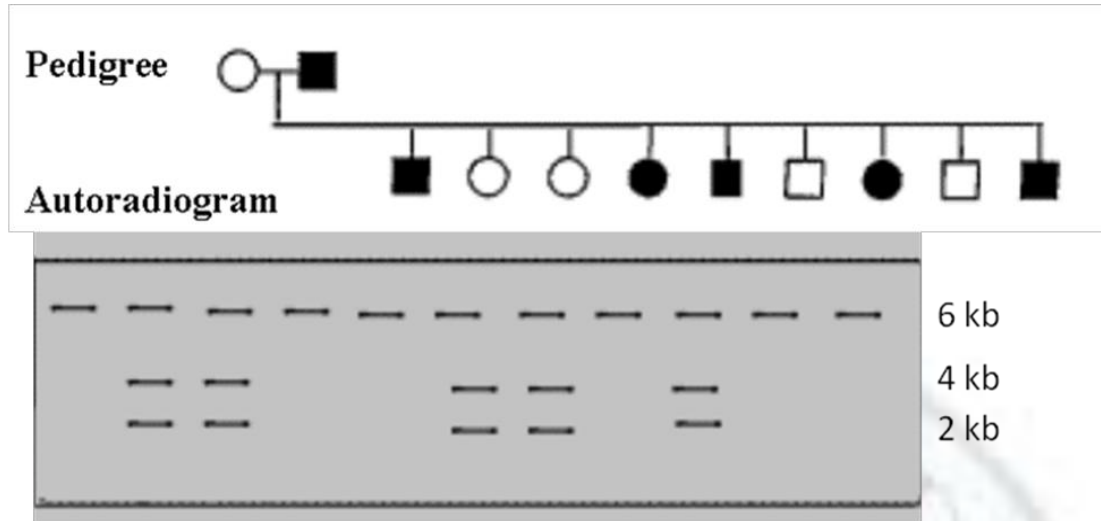

**Figure:** Pedigree and the southern blot comparison of the individuals by RFLP analysis. The black represents diseased individuals. The first and second lanes in the autograph show the profile of parents and the rest of the lanes show restriction profile of the progenies. It can be observed that the mutation is autosomal dominant and inherited through the male parent.

Source: Author

- **Identification of a target gene**

It is mostly used for identifying a gene cloned by using specific primers for that gene. The number of bands obtained in an autoradiograph can also identify the number of copies integrated in the genome.

- **Use in forensic science**

Southern blotting can be used to detect criminals by analyzing the DNA sample under investigation. It can also be used in paternity testing by analyzing the genetic pattern.

- **Genetic mapping**

Restriction fragment length polymorphism (RFLP) analysis is done by using Southern blotting. It can be used to make genome maps (Botstein et al., 1989).

- **Dot/ slot blot analysis**

In a dot blot or slot blot analysis, the only difference from southern hybridization is that the samples are not electrophoresed prior to immobilization on the membrane and used as such for hybridization. This method is used for detection of a particular DNA molecule in a mixture of DNA samples.

## Blotting Techniques

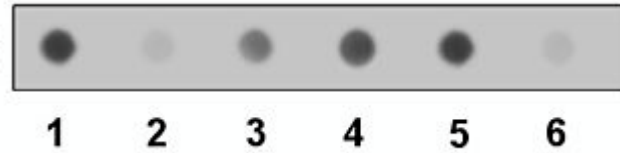

**Figure:** A dot blot filter showing result of hybridization of a membrane containing the dots of different DNA samples, after hybridization with a particular probe.

Source: [http://en.wikipedia.org/wiki/Dot\\_blot#mediaviewer/File:DotBlotDemo.jpg](http://en.wikipedia.org/wiki/Dot_blot#mediaviewer/File:DotBlotDemo.jpg)

The first hybridization chamber was a homemade device. It consisted of a rotating wheel placed in an oven at 65°C. The nitrocellulose paper was placed in a glass tube along with a hybridization solution and kept to rotate for 18 hours.

## Northern Blotting

### Introduction

Northern blot is a technique used to detect specific RNA from a mixture of RNA. The RNA is immobilized on the membrane and detected using specific probes. It can be used to measure the amount of RNA to relate with the gene expression of that RNA. It was developed by James Alwine in 1977 at the Stanford University. It does not require the digestion of RNA with restriction enzymes. Formaldehyde is used to break H-bonds and denature RNA.

## Blotting Techniques

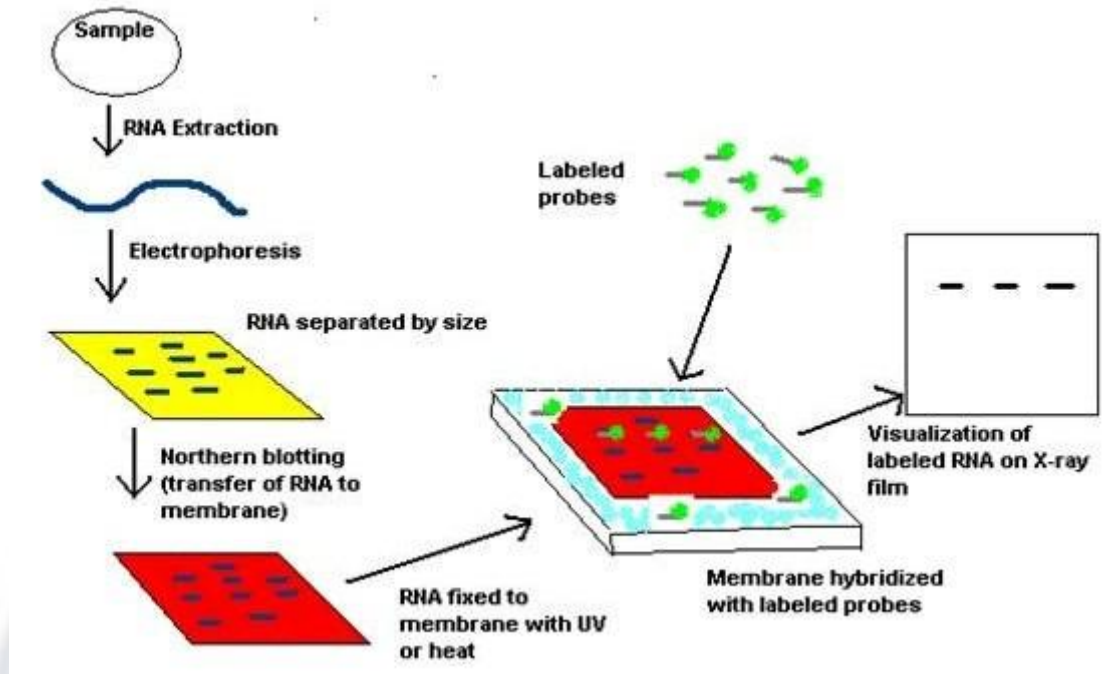

Figure: Steps in Northern blotting. Source:

[http://en.wikipedia.org/wiki/Northern\\_blot#mediaviewer/File:Northern\\_Blot\\_Scheme.PNG](http://en.wikipedia.org/wiki/Northern_blot#mediaviewer/File:Northern_Blot_Scheme.PNG) (cc)

Animation: <http://vimeo.com/channels/563554/69633383>

The S in the Southern Blot is always capitalized as the technique is named after Sir Edwin Southern who developed it in 1975. However the w in western and n in northern is not capitalized.

## Procedure

The process involves the following steps

1. Extraction of RNA
2. Gel electrophoresis
3. Membrane transfer
4. Detection

# Blotting Techniques

## 1. Extraction of RNA

RNA is more labile than DNA both chemically and biologically therefore RNases is eliminated in the extraction procedure. The RNA is extracted from a tissue sample by homogenization (crushing of sample tissue) or by using oligo (dT) cellulose chromatography.

Oligo (dT) cellulose chromatography- This technique involves separation of mRNA based on the complimentary attachment. The mRNA in the cell is modified by attaching poly A nucleotides at the 3' end. A chromatographic column is prepared using cellulose as the matrix and dT tails are attached. The mRNA poly A is passed through the column and gets attached to the dT based on the complementarity. The samples are then eluted to get the sample RNA.

## 2. Gel electrophoresis

It is performed to separate the RNA samples.

## 3. Membrane transfer

The RNA is transferred to the nylon or nitrocellulose membrane. The technique used is similar to the one used in the southern blotting. The transfer may be done using capillary transfer, electrophoretic transfer etc. The binding capacity of nitrocellulose is -100ug/cm and that of nylon is 500ug/cm. The RNA is cross linked to the membrane by UV light or baking at 80°C.

## Probe labeling

The probes used to find the target RNA can be of the following types:

- Radio labeled- these are attached to the P32 molecule.
- *In vitro* transcribed RNA- these are designed against the target RNA *in vitro*.
- Synthetic oligonucleotides- These are artificially designed against the target RNA if the sequence is already known.

Partial homologous sequence- The complementarity is not complete but partial. These are not specific but are partially bound.



# Blotting Techniques

## 4. Detection

The detection can be:

- **Radioactive:** The probe used is  $^{32}\text{P}$ . It binds to the target RNA. The membrane is placed over the X-Ray film. The bound sequence is radiolabelled and can be detected on an autoradiograph. The darkened bands correspond to the fragments complimentary to the probes.
- **Non radioactive:** the probes used are bioluminescent or enzyme linked.

## Applications

- To analyze gene expression pattern in specific conditions under which the genes are being expressed.
- To detect the size of mRNA transcript.
- To study RNA detection.
- To detect over expression of oncogenes.
- To study RNA splicing by studying alternative splice products.
- To study IRES (internal ribosomal entry site).
- To check deletion or errors by checking the size of the product.
- To check and confirm transgenic /knockouts.

Table: The advantages and disadvantages of Northern Blotting

Criteria	Advantages	Disadvantages
Sensitivity	Fast and cheap	Less sensitive than RT-PCR
Isolation of sample	Less manipulation required while isolation of RNA	Sensitive to degradation
Probe labeling	Probes used:	Multiple probes cannot be

## Blotting Techniques

	<ul style="list-style-type: none"><li>• Radio labeled</li><li>• <i>In vitro</i> transcribed RNA</li><li>• Partially homologous sequence</li><li>• synthetic oligonucleotides</li></ul>	used.
Detection	Transcript size determined quantify RNA	It does not measure RNA stability or transcription rates

Source: Author

## Western Blotting

### Introduction

Western blotting, also known as immunoblotting or protein blotting is used to detect a specific protein from a complex mixture of a cell extract. It was first described by Towbin et.al in 1979. It relies on three basic elements:

- Separation of proteins by size.
- Transfer of separated proteins on a solid membrane.
- Specific detection of target protein.

After detection the protein is visualized as a band on the membrane or X-ray film.

It is commonly used in laboratory as it is rapid, requires simple equipment and inexpensive reagents. The results are easy to interpret, unique and unambiguous.

## Blotting Techniques

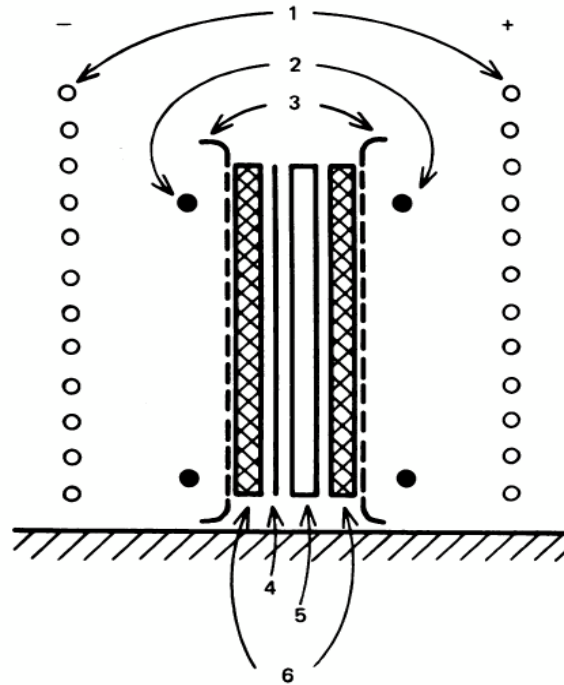

FIG. 1. Assembly for electrophoretic blotting procedure. 1, Electrodes of destainer; 2, elastic bands; 3, disposable pipette-tip tray; 4, nitrocellulose sheets; 5, polyacrylamide gel; 6, Scotch-Brite pads. Assembly parts are shown separated for visualization only.

**Figure:** The first assembly apparatus for Western Blot given by Towbin et. Al 1979

Source: <http://www.ncbi.nlm.nih.gov/pmc/articles/PMC411572/pdf/pnas00009-0198.pdf>

## Principle

It is an analytical technique where the protein sample is run on an SDS-PAGE and transferred to a solid membrane. The transferred protein is detected by a specific primary and secondary labeled antibody. These antibodies bind to a specific sequence of amino acids. As the amino acid sequences differ from protein to protein, these can help target specific proteins in a complex mixture. First proteins are separated on the basis of size. Second antibodies are used to identify the target protein. Lastly a substrate reacting with the enzyme is used for the protein/antibody complex detection.

Video: <https://www.youtube.com/watch?v=X0izdqNWgCo>

# Blotting Techniques

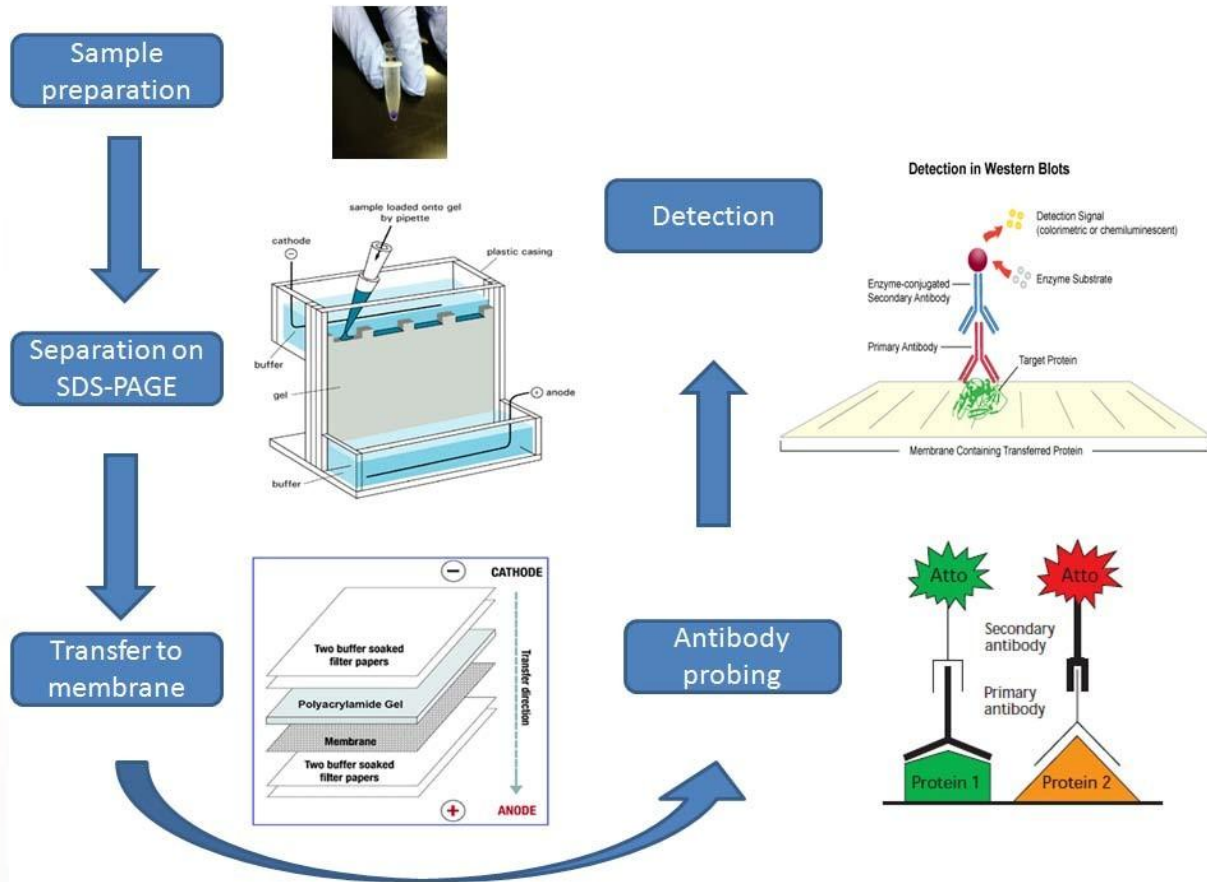

**Figure:** Workflow of Western Blotting

Source: Author

## Methodology

The technique involves isolation of the protein sample and its separation through SDS-PAGE. The separated bands are then transferred onto the membrane. The membrane is blocked to avoid non specific binding and is the labeled with specific labeled antigens. These are then detected based on radioactive or non radioactive methods.

The method comprises of the following steps:

1. Sample preparation
2. Separation on gel
3. Transfer to the blotting membrane



## Blotting Techniques

4. Blocking
5. Antibody incubation
6. Detection

### 1. Sample preparation

The samples are denatured in gel loading buffer containing SDS detergent and hence they carry a uniform negative charge. The samples can be of three different types.

- **Cell lysates**- Crude cellular lysates are the most common source for Western blotting. The cells are harvested washed and lysed to release the target protein.

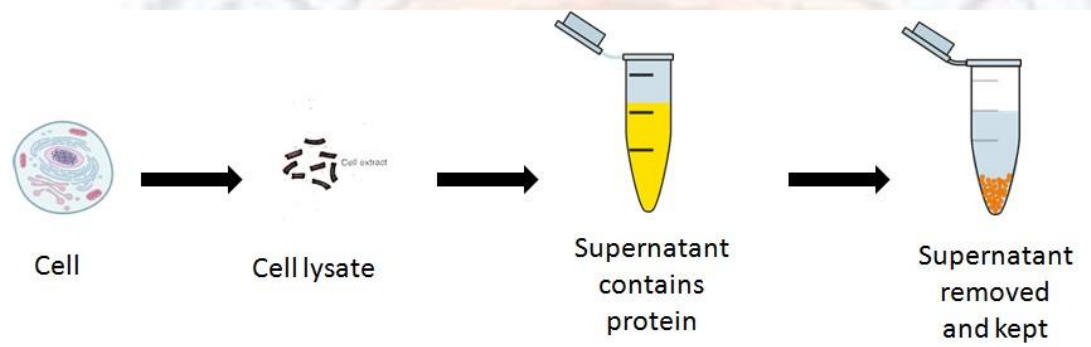

Figure: Preparation of sample extracts

Source: Author

- **Tissue samples**- They require higher level of mechanical disruption in order to release the protein of interest. The tissue is homogenized and lysed; the solubilized cellular components are centrifuged. The protein sample obtained is tested for concentration.
- **Purified or semi-purified extracts**- These are the simplest source of starting material obtained during the course of protein purification.

**Determining protein concentrations**- It is important to know the concentration of total protein in the sample for a proper range of detection in the assay. The simplest method is to check the absorbance of the lysate at 280 nm and 205 nm. Alternatively Lowry, BCA, Bradford assays can be used against a standard such as BSA.



# Blotting Techniques

## Controls

Proper control design is necessary to ensure the accuracy and specificity of the test result.

- **Positive control:** A sample known to express the test protein. It is to test the efficiency of the antibodies used.
- **Negative control:** A sample not known to express the test protein. It rules out the probability of non-specific binding and false positives.
- **Secondary antibody control:** The primary antibody is not added. It is to check the specificity of secondary antibody.
- **Blank control:** Both the primary and secondary antibodies are not added. It is to check the membrane nature and blocking effect.
- **Loading control:** It is to check the sample quality and ensure proper loading in gels. Housekeeping genes' antibodies are used as loading control.

## 2. Separation

### SDS-PAGE (sodium dodecyl sulphate polyacrylamide gel electrophoresis)

Electrophoresis describes a phenomenon where charged ions move towards opposite electrodes in the presence of an electric field. It is used to separate proteins according to their electrophoretic mobility which depends on charge, molecular size and structure of the proteins. Polyacrylamide gel (PAG) is a three-dimensional mesh network and is neutrally charged. SDS is an anionic detergent which breaks the hydrogen bonds between the protein molecules therefore breaking up the secondary and tertiary structures. As all the proteins are differently charged SDS treatment gives a uniform negative charge to the proteins (it is a denaturing agent also). Strong reducing agents like mercaptoethanol and DTT (dithiothreitol) are used to disrupt the disulfide linkages between cysteine residues. Thus the SDS-protein mobility depends on the molecular weight only. PAGE is used to separate proteins of 5 to 2000kDa. Pore size is controlled by varying the concentration of the gel. The smaller the weight higher is the percentage of the gel to be used.

As the protein samples are negatively charged they migrate towards the positive electrode in the presence of an electric field.

SDS-PAGE gels consist of a main gel and a stacking gel poured between two glass plates. The percentage and thickness of gel varies according to the proteins to be separated.

## Blotting Techniques

The buffer system with different pH values is used in the process. eg: Laemmli system that stacks at pH 6.8 and resolves at a pH 8.3-9.0.

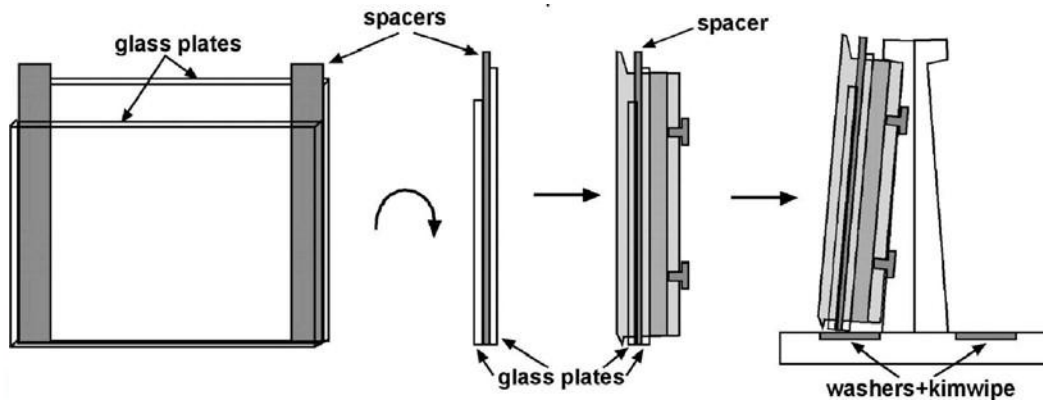

**Figure:** The arrangement of glass plates for the gel apparatus Source:

[http://www.wormbook.org/chapters/www\\_immunohistochemistry/immunohistochemistry.html](http://www.wormbook.org/chapters/www_immunohistochemistry/immunohistochemistry.html)

After the gel is poured, the samples (5-20 $\mu$ l) are loaded onto the wells and the apparatus is connected to a power supply. A molecular weight marker is loaded in one of the wells to analyze the weight of the test protein.

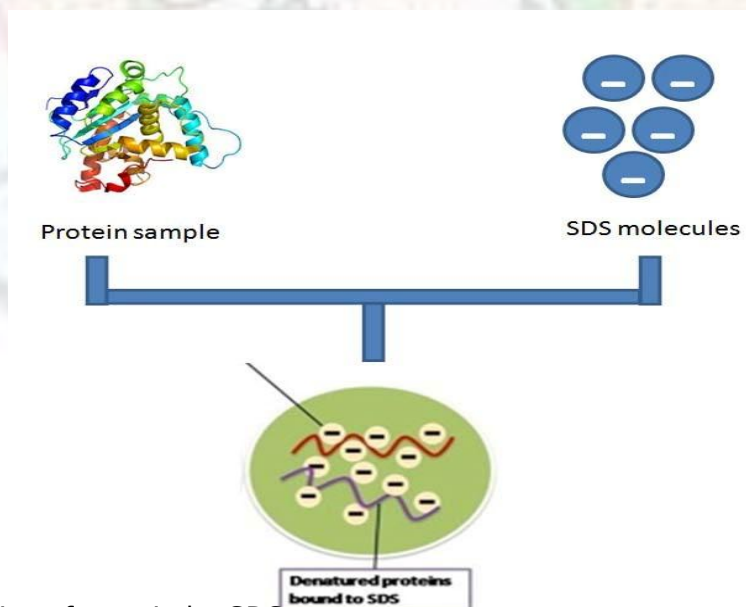
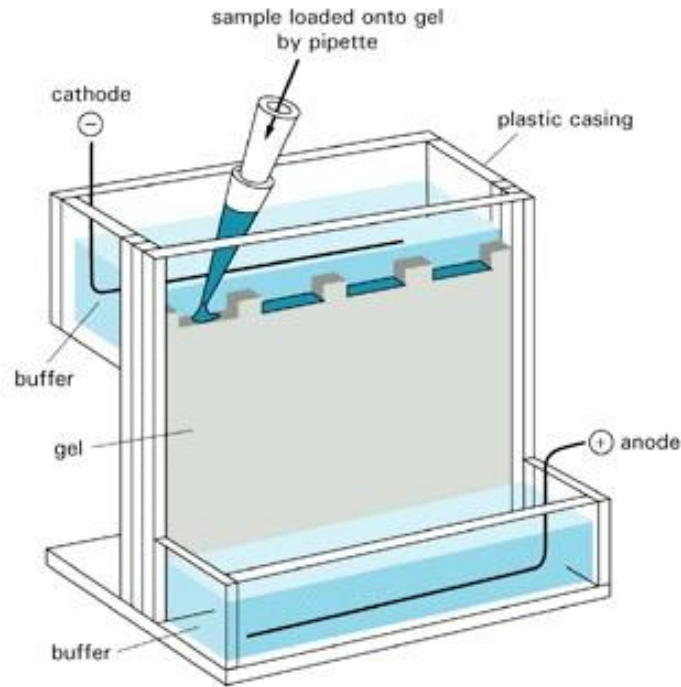

Figure: Denaturation of protein by SDS

# Blotting Techniques

Source: Author



**Figure:** Migration of protein samples in the SDS-PAGE

Source: [http://openwetware.org/wiki/Protein\\_blot\\_\(Western\)](http://openwetware.org/wiki/Protein_blot_(Western)) (cc)

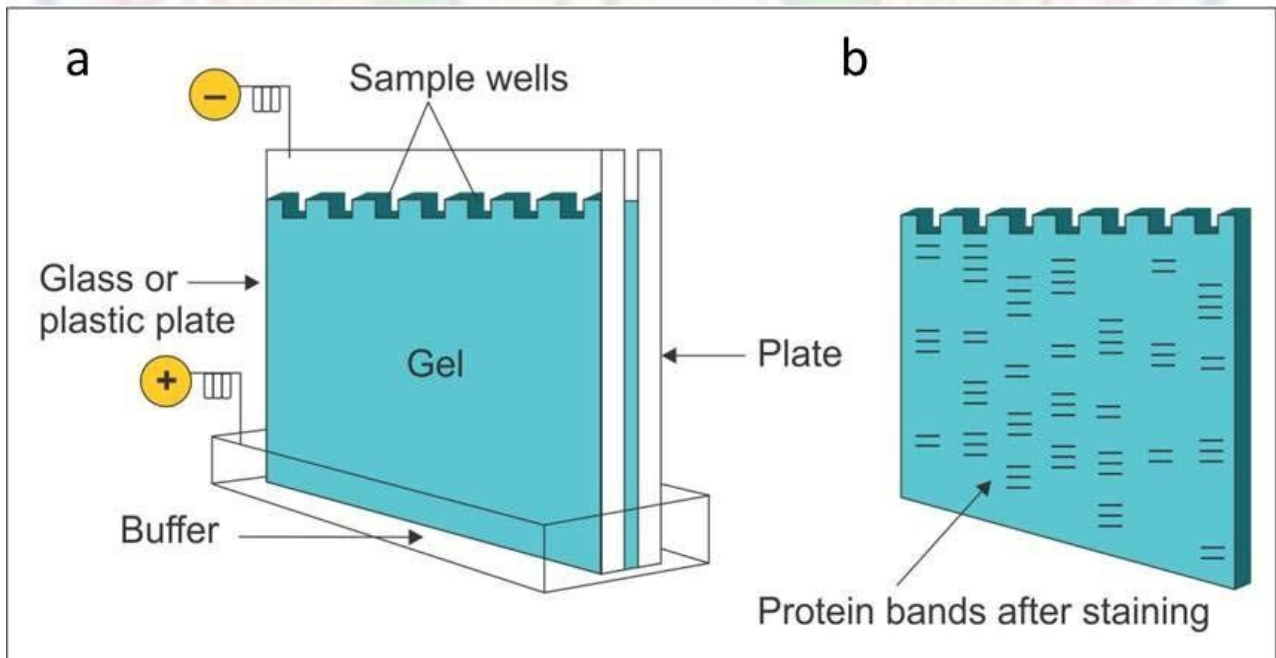

**Figure:** Separation of protein sample on the gel.

## Blotting Techniques

Source: <http://www.afrivip.org/education/health-management-tools/laboratory-diagnostics-molecular/molecular-blotting/2014/highlights> (CC)

### 3. Blotting

After the protein mixtures are separated, they are transferred to a solid support for further analysis. Different blotting membranes and methods of transfer are described below

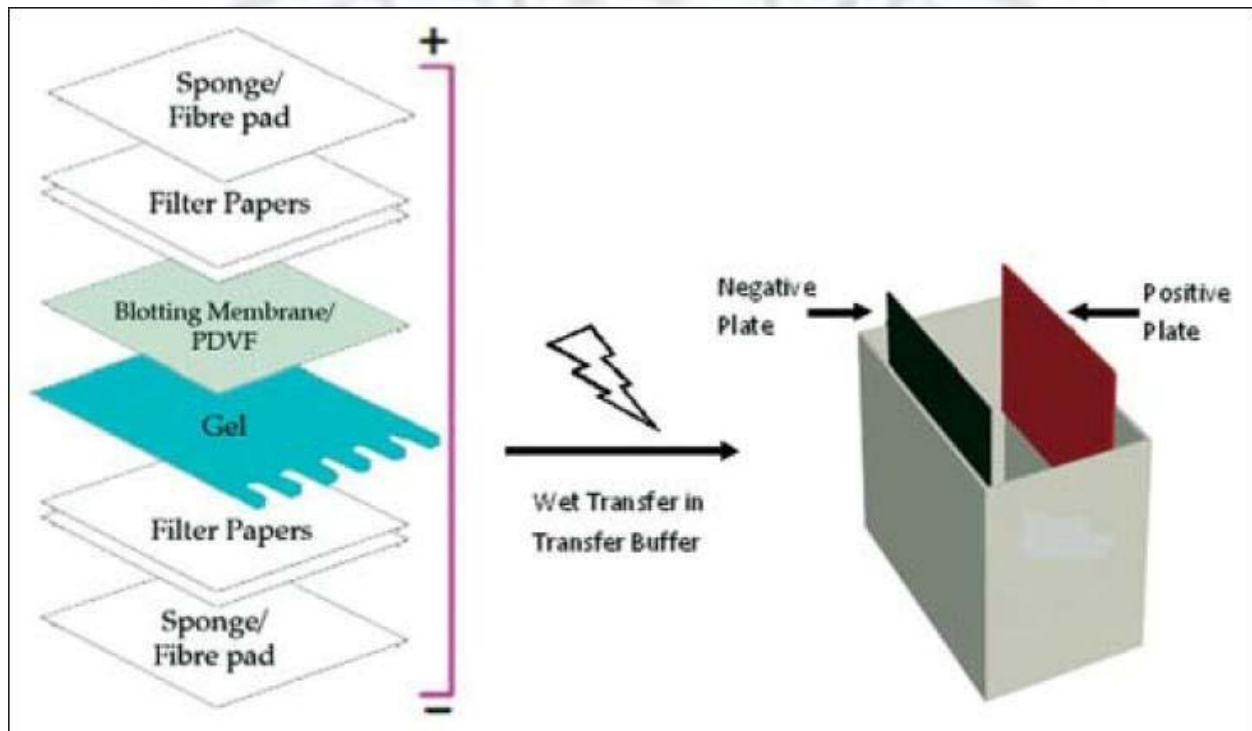

Figure: Sandwich arrangement of the membrane and wet transfer in a buffer

Source: <http://www.najms.org/article.asp?issn=1947-2714;year=2012;volume=4;issue=9;page=429;epage=434;aulast=Mahmood> (cc)

- **Membranes**

- ✓ **Nitrocellulose-** It is most commonly used. But it has certain disadvantages, the proteins are not covalently bound, it is brittle when dry and smaller proteins tend to move through the membrane therefore only a small amount binds actually. It has been improved by using a gelatin coated membrane for



## Blotting Techniques

quantitative retention and has shown increased strength by incorporating a polyester support web.

- ✓ **Polyvinylidene difluoride (PVDF)** - It has higher binding capacity, physical strength and chemical stability. Unlike nitrocellulose membrane it can be stained with Coomassie Brilliant Blue (CBB)
- ✓ **Activated paper (diazo groups)** - It binds to proteins covalently but is not compatible with many gel electrophoresis systems. It is expensive and has a limited half life.

### • Methods of transfer

- ✓ **Simple diffusion**-In this process the membrane is laid on the gel surface with a stack of dry filter paper on the top. A certain weight is placed on the apparatus to enhance diffusion. The drawback is that there is no quantitative transfer.

It has been shown that it transfers 20-25% of the proteins to the membrane and can be used to obtain multiple blots.

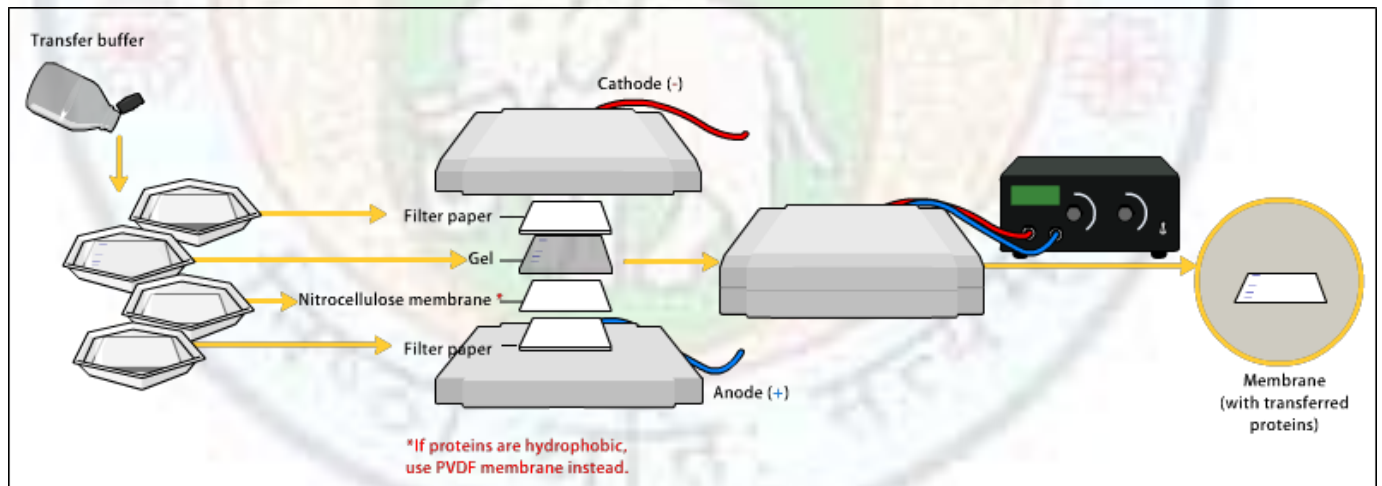

**Figure:** Setup for a gel membrane transfer in western blotting

Source: [http://en.wikipedia.org/wiki/File:Western\\_blot\\_transfer.png](http://en.wikipedia.org/wiki/File:Western_blot_transfer.png)

(cc)



## Blotting Techniques

- ✓ **Vacuum blotting-** It uses the suction power of the pump connected to a slab gel-dryer system to move the separated polypeptides from the gel to the nitrocellulose membrane. More amount of buffer is used to prevent gel drying.
- ✓ **Electro blotting-**It is most commonly used. Its advantages are speed and the complete transfer of proteins as compared to the other methods.
  - **Wet transfer-** it involves complete immersion of the gel membrane sandwich in a buffer.
  - **Semi-dry transfer-**the gel membrane sandwich is placed between carbon plate electrodes. It is advantageous as less power is required, electrodes are cheap and multiple blots can be prepared.

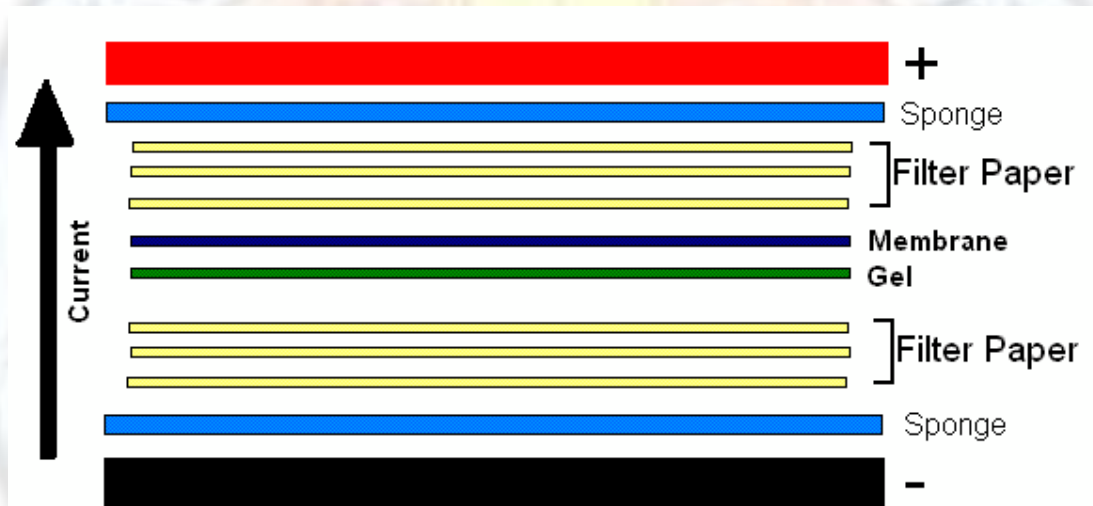

Figure: Electroblotting

Source: <http://en.wikipedia.org/wiki/Electroblotting#mediaviewer/File:Electroblot.gif>

(cc)

### 4. Blocking

After the transfer of the protein the blot is incubated with a blocking solution. The non specific protein binds to the sites not occupied by the test protein. This prevents the non specific binding of the antibody to the membrane. 3-5%BSA or non-fat dried milk in PBS (phosphate buffered saline) or TBS (tris buffered saline) is used.

## Blotting Techniques

### 5. Antibody incubation

After blocking and washing the blot is incubated in a dilute solution of antibody for a few hours or overnight at 4°C.

### 6. Detection

- **Organic Dyes**-Ponceau red, amido black, fast green, CBB are commonly used dyes.
- **Immunodetection**- Two methods are used after the blocking of the primary antibodies.
  - **Radioactive:** The antigen-antibody reaction can be visualized by using a radioactively labeled isotope as a secondary antibody. It is easy to quantify by means of timed exposure and densitometry or directly by scintillation counter. The autoradiographed image can be easily reproduced.
  - **Enzyme linked reagents:** It is the most popular method and uses horseradish peroxidase or alkaline phosphatase coupled antibodies. They are easy to use but cannot be used for quantification.

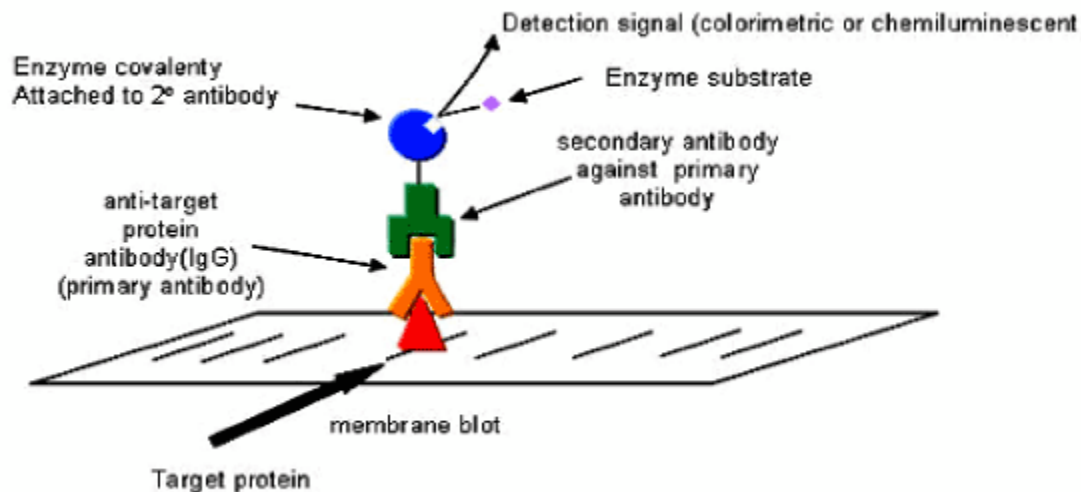

## Blotting Techniques

**Figure:** The identification of proteins is done by separating them on SDS agarose and binding them to the membrane. The detection is done using a labeled antibody against the specific antigen.

Source: <http://omicsonline.org/open-access/antihuman-igghorseradish-peroxidase-conjugate-preparation-and-its-use-in-elisa-and-western-blotting-experiments-2157-7064.1000211.php?aid=24109>

CC

- **Gold:** Protein A bound to gold particles has been used. After incubation with the primary antibody staining with protein gold gives red color.

## Applications

It can be used for research and medical diagnosis purposes.

- It can identify the nature of protein and is also used for quantification.
- It can be used in epitope mapping to identify and characterize the binding sites. This can be useful for developing new therapeutics, diagnostics and vaccines.
- To test the endogenous and exogenous expression of a protein.
- Structure domain analysis.
- To demonstrate antibody specificity.
- To confirm HIV-positive individuals by using a secondary anti-human antibody conjugated with a signal which detects the presence of HIV in the patient.
- It is used in the detection of Lyme disease along with ELISA.
- Detection of Bovine Spongiform Encephalopathy (BSE) using specific T1 antibody.
- Detection of FIV in cats.
- As a confirmatory test in Hepatitis B infection.
- Detection of Herpes in humans.

## Blotting Techniques

### Eastern Blotting

It is used to study the post translational modification. Post translational modifications are essential for study in several diseases. Proteins are blotted from 2-D SDS-PAGE to a PVDF or nitrocellulose membrane. The probes are specifically designed to detect lipids, carbohydrates and phosphomoieties. It was developed by S. Thomas while working on Ehrlichia at University of Texas.

### Glossary

**Antibody:** It is a protein which binds to a specific antigen.

**Autoradiograph:** A photograph of an object which detects the radioactive signal in the sample.

**DNA hybridization:** Formation of a double stranded DNA from two single stranded molecules

**Immobilization:** Confining the molecule on a solid support.

**Lysis:** Cell degradation by rupturing the cell wall or membrane.

**Lysate:** The cell product left after lysis.

**Restriction enzyme:** Enzymes that can cleave a DNA molecule at a specific site in a sequence.

**Denaturation:** The process involves breaking of the quaternary tertiary or secondary structure of a molecule.

**Crosslinking:** A chemical or covalent bond formed between two molecules.

**Complimentary sequence:** The sequence of nucleic acids that can form a double stranded structure.

**Radioactivity:** It is a phenomenon of emitting ionizing radiation.

**Fluorescence:** It involves absorbance of lower wavelength light and emission of higher wavelength of light.

**Oligonucleotides:** Polynucleotide containing small number of nucleotides.

**Cell extract:** The product obtained after the removal of cell debris.

**SDS-PAGE:** The technique used to separate proteins on gel.

**Primary antibody:** Protein that contains two binding sites, one for the target molecule and the other for a signal linked secondary antibody.

**Secondary antibody:** Protein molecule that contains a site for binding to the primary antibody and a site for binding to the signal molecule.

**Nitrocellulose:** Chemical made by the reaction of nitric acid on cellulose.



## Blotting Techniques

**Blotting:** Nitrocellulose or nylon membrane to which the DNA/RNA or protein molecule is immobilized

**Gel electrophoresis:** The process of passing electric current through a gel which separates the nucleic acids based on their charge and mass ratio

**Blocking:** Treating the blotting membrane with a chemical so that it is unreactive towards the labeled probes.

**Lysis buffer:** Solution used to break the cell membrane and release cell contents.

**Probe:** Small DNA fragment used to determine if the complementary sequence is present in a DNA sample.

### Exercise

- What is the principle of Southern Blotting?
- Explain the methodology of Southern Blotting.
- What are the applications of Southern blotting?
- What is the procedure of northern blotting?
- What are the advantages and disadvantages of western blotting?
- What are the applications of western blotting?
- What types of membranes are used in blotting?
- What are the different ways of transfer in blotting?



## Blotting Techniques

### References

- Hayes, Peter C., C. Roland Wolf, and John D. Hayes. "Blotting techniques for the study of DNA, RNA, and proteins." *BMJ: British Medical Journal* 299.6705 (1989): 965.
- Turner, Phil, et al. *BIOS Instant Notes in Molecular Biology*. Taylor & Francis, 2007.
- Towbin, Harry, Theophil Staehelin, and Julian Gordon. "Electrophoretic transfer of proteins from polyacrylamide gels to nitrocellulose sheets: procedure and some applications." *Proceedings of the National Academy of Sciences* 76.9 (1979): 4350-4354.
- Brown, T. A. "Gene cloning: an introduction." *Gene cloning: an introduction*. Ed. 3 (1995).

### Further reading

<https://askabiologist.asu.edu/southern-blotting>

<http://www.web-books.com/MoBio/Free/Ch9C.htm>

[https://sites.google.com/a/biogoggles.co.cc/biogoggles/rdna-techniques/blotting-](https://sites.google.com/a/biogoggles.co.cc/biogoggles/rdna-techniques/blotting-techniques)

[techniques https://sites.google.com/a/biogoggles.co.cc/biogoggles/rdna-](https://sites.google.com/a/biogoggles.co.cc/biogoggles/rdna-techniques/northern-blot)

[techniques/northern-blot](https://sites.google.com/a/biogoggles.co.cc/biogoggles/rdna-techniques/northern-blot) [http://www.najms.org/article.asp?issn=1947-](http://www.najms.org/article.asp?issn=1947-2714;year=2012;volume=4;issue=9;spage=429;epage=434;aulast=Mahmood)

[2714;year=2012;volume=4;issue=9;spage=429;epage=434;aulast=Mahmood](http://www.najms.org/article.asp?issn=1947-2714;year=2012;volume=4;issue=9;spage=429;epage=434;aulast=Mahmood)

